

NPR-HD Gas

CREW CAB

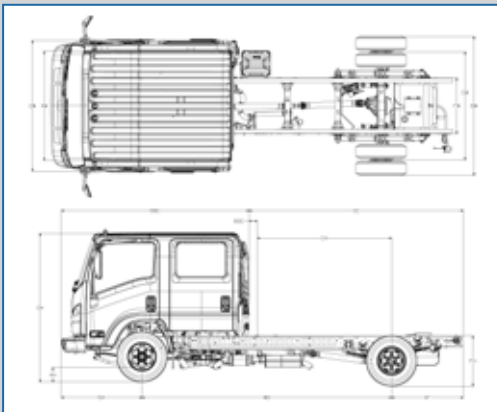

Wheelbase (in.)	Cab to Axle (in.)	Cab to End of Frame (in.)	Back of Cab (in.)	Overall Length (in.)	Body Length (ft.)	Overall Width (in.)	Axle Width (in.)	Overall Height (in.)
1500	88.5	131.6	5.0	241.5	12	81.3	65.6	91.1
1760	114.5	157.6	5.0	267.5	16	81.3	65.6	91.1

2017 ISUZU N-SERIES GAS WARRANTY COVERAGE AT A GLANCE

Vehicle Coverage	Warranty Limitations (Time or Mileage, Whichever Comes First)*		Percentage of Dealer's Normal Charge Paid by Owner	
	Time in Years*	Vehicle Miles*	Parts	Labor
Basic	0-3 Years	0-36,000	No Charge	No Charge
Engine	0-5 Years	0-75,000	No Charge	No Charge
• Transmission • Drive Axle • Driveshaft • Front Axle I-Beam • Crossmembers	0-5 Years	0-75,000	No Charge	No Charge
Frame Rails	0-3 Years	0-36,000	No Charge	No Charge
	3-5 Years	Unlimited	50%	50%
Federal Emissions	0-5 Years	0-50,000	No Charge	No Charge
Tires	0-2 Years	0-24,000	No Charge	No Charge
Corrosion (Rust Through)	0-4 Years	Unlimited	No Charge	No Charge

* The warranty coverages are determined by the mileage of the vehicle and the number of years from the delivery date. See your authorized Isuzu dealer for warranty details.

GVWR/GCWR	14,500/20,500 lbs.
BODY/PAYLOAD ALLOWANCE	8,442 - 8,503 lbs.
GAWR	
Front	6,630 lbs.
Rear	11,020 lbs.
FRONT AXLE CAPACITY	6,830 lbs.
REAR AXLE CAPACITY	11,020 lbs.
Ratio	5.375
SUSPENSION F/R SPRINGS	Tapered/Multi-Leaf
Capacity	8,440/12,900 lbs.
FRAME	
Section Modulus	7.20 in. ³
Resistance Bending Moment	316,800 lb.-ft./in.
SERVICE BRAKES	Vacuum/Hydraulic with 4-Channel ABS Disc/Drum
Front/Rear	
TRANSMISSION	6L90 6-speed auto. with double overdrive and lock-up converter
ENGINE	GMPT L96 (Gen IV) V8 Vortec 6000 (Optional: KL8 - Alternative Fuel Capable Engine)
Displacement	6.0L (365 in. ³)
Engine Power	297 hp @ 4,300 rpm
Engine Torque	372 lb.-ft. @ 4,000 rpm
LIMITED SLIP DIFFERENTIAL	Optional
ALTERNATOR	145-amp
BATTERIES	1 Maintenance-Free 750-CCA
TIRES LRR (Low Rolling Resistance)	225/70R19.5G (14-pr) Standard
STEERING	Integral Hydraulic Power
STEERING COLUMN	Tilt and Telescopic
FUEL TANK	30 gal. in-frame
Standard	

